

A SUCCESSFUL COMBINATION THAT ALLOWS 4 WORKS

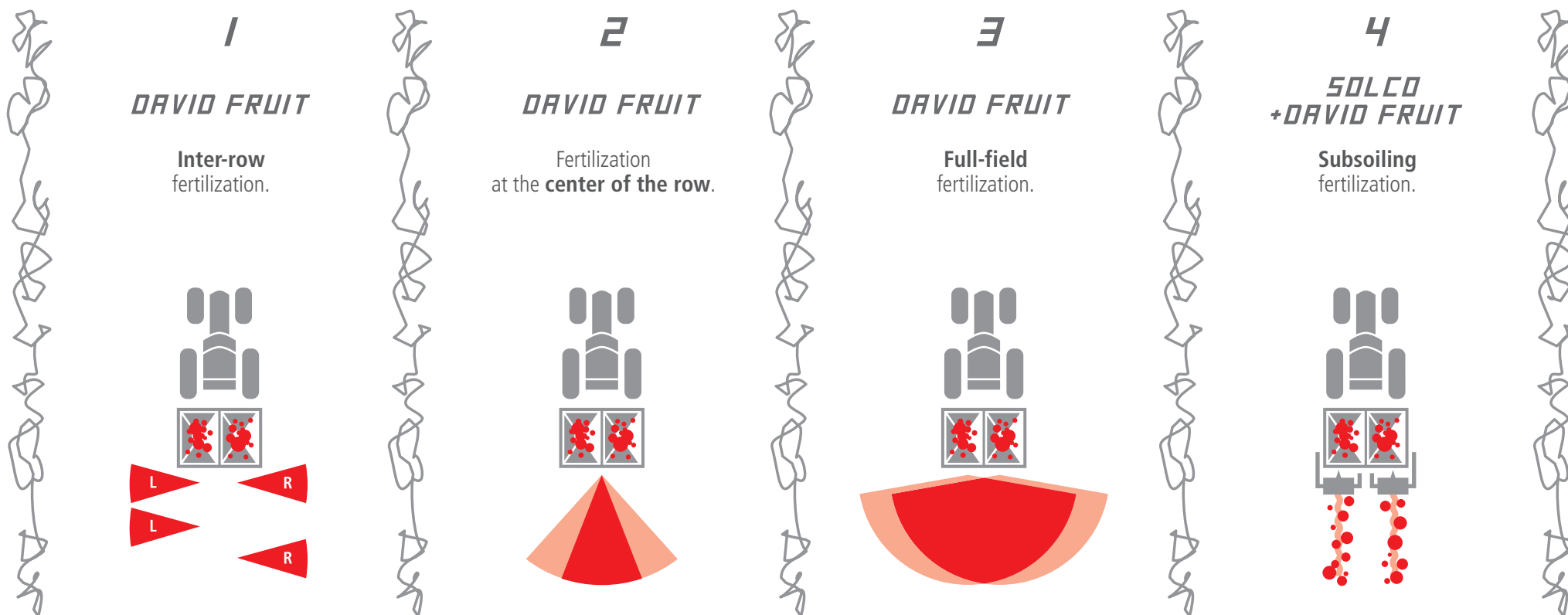

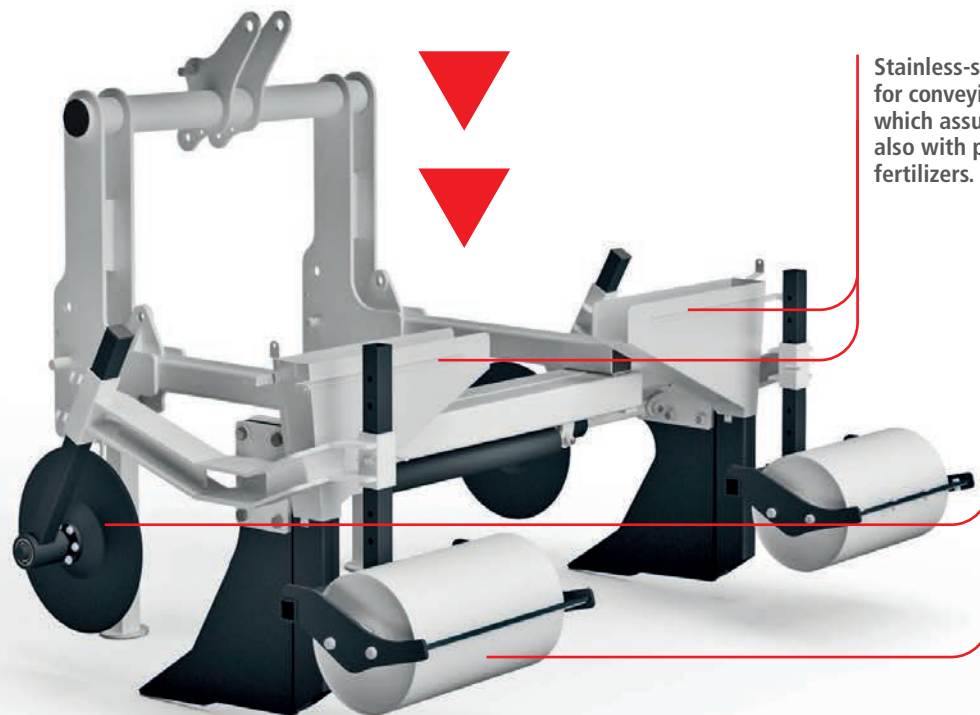

Stainless-steel wide ducts for conveying the fertilizer, which assure high flows also with pelleted fertilizers.

Front discs for the prior cut of the soil and rear roller for the close and compaction of the groove (attachments on request). Both with adjustable height.



SOLCO

+ DAVID FRUIT



STRUCTURAL
STURDINESS



ANTICORROSIVE
TREATMENTS



HYDRAULIC
DRIVES



VARIABLE LENGTH



WORKING DEPTH



HITCHING CATEGORY



WEIGHT

The stainless-steel conveyors allow the assembly on the *David fruit* fertiliser spreader (versions from 2012 onwards), **for subsoil fertilization**.

Thanks to the **variable width** - by means of **hydraulic cylinders** - it is possible to easily change the subsoiling width directly from the tractor, to adapt to any type of row.

PVC bellows assure the complete fertilizer flow without accidental spillage with any spreading width.

Sturdy tines with wear-resistant material filler.

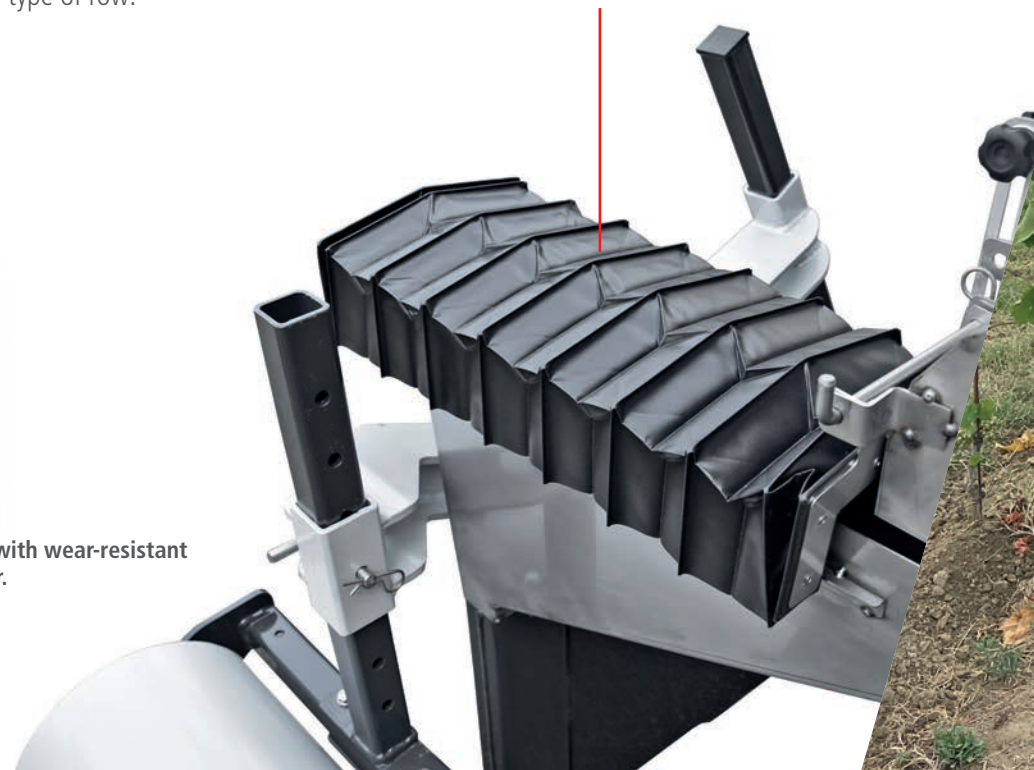
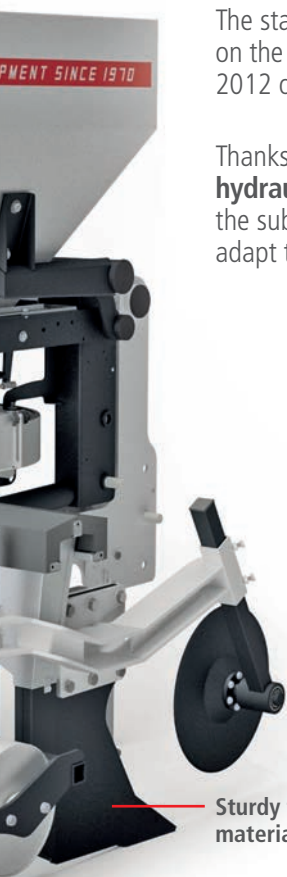

ACCESSORIES

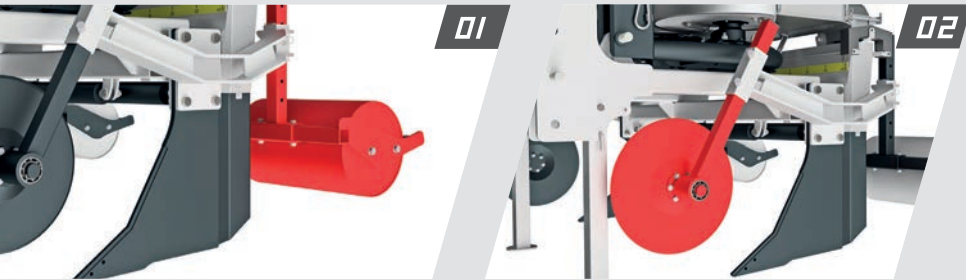

01

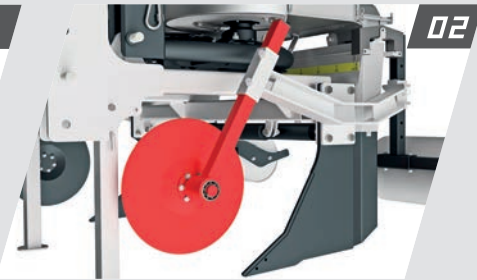

02



03

- 01 – REAR ROLLERS
- 02 – FRONT DISCS
- 03 – DISCS OR ROLLER SUPPORTS

SOLCO

SOLCO

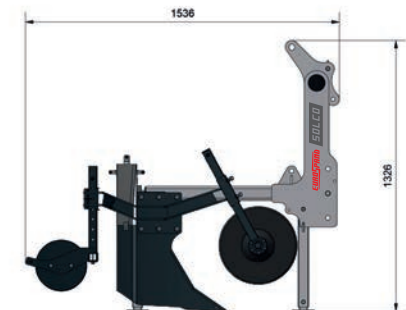
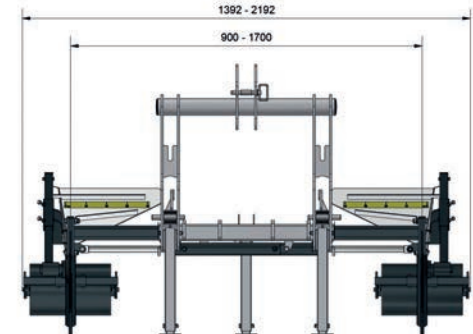

SOLCO + DAVID FRUIT

